

Test Methods: ASTM D6638 & NCMA SRWU-1
 Geogrid Type: Miragrid 8XT
 Block Type: Positive Connection (PC) Block

Test Facility: Bathurst, Clarabut Geotechnical Testing, Inc.
 Test Date: December 16, 2011

CONNECTION STRENGTH TEST DATA ^(a)

Test No.	Normal Load, lb/ft	Peak Connection, lb/ft	Observed Failure
1	1,960	7,995	Rupture
2	241	7,949	Rupture
3	1,125	7,904	Rupture
4	2,036	7,949	Rupture
5	2,914	8,269	Rupture
6	3,715	7,995	Rupture
7	1,900	8,452	Rupture
8	4,551	8,269	Rupture

Peak Connection _(average) = 8,098 lb/ft
 Peak Connection _(95% confidence level) = 7,928 lb/ft ^(b)

MIRAGRID 8XT CONNECTION STRENGTH

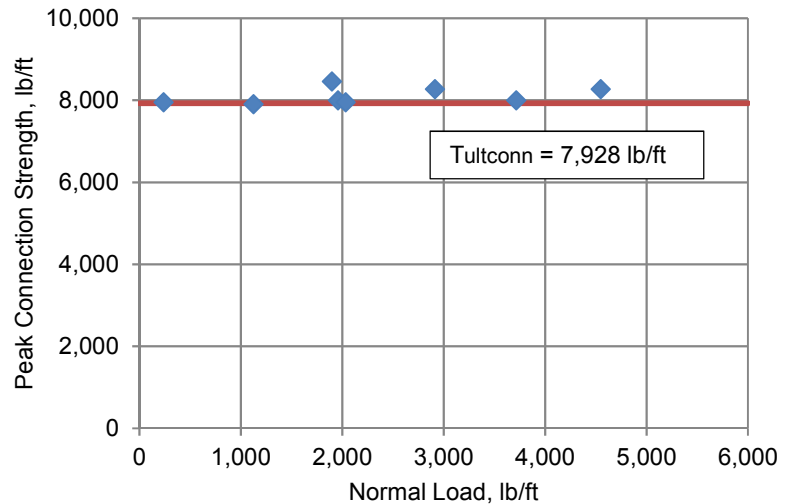

CONNECTION DESIGN DATA

for use with AASHTO LRFD Bridge Design Specifications, 6th Edition (2012)

Miragrid 8XT Ultimate Tensile Strength (MARV)	$T_{ult} = 7,400$ lb/ft
Ultimate Connection Strength	$T_{ultconn} = 7,928$ lb/ft
Ultimate Tensile Strength of Geosynthetic Test Sample	$T_{lot} = 8,055$ lb/ft
Connection Strength / Sample Strength	$T_{ultconn} / T_{lot} = 0.98$
Short-term Ultimate Connection Strength Reduction Factor ^(c)	$CR_u = 0.84$
Creep Reduction Factor	
75-Year Design	$RF_{CR(75)} = 1.56$
100-Year Design	$RF_{CR(100)} = 1.58$
Durability Reduction Factor ^(d)	$RF_D = 1.15$
Long-term Connection Strength Reduction Factor	
75-Year Design	$CR_{cr(75)} = 0.54$
100-Year Design	$CR_{cr(100)} = 0.53$
Nominal Long-term Geosynthetic Connection Strength	
75-Year Design	$T_{ac(75)} = 3,465$ lb/ft
100-Year Design	$T_{ac(100)} = 3,421$ lb/ft



- (a) Tested with 3/4" clean crushed stone lightly compacted in the vertical core slot in accordance with Redi-Rock's typical installation recommendations.
 (b) Because the geogrid connection is not normal load dependent and an expression of peak connection for use in design cannot be reliably determined through linear regression, the peak connection results are analyzed as continuous random variables. The average value or sample mean is reported for the test sample as well as a reduction based upon a 95% confidence interval calculated from the Student's t-test for n-1 degrees of freedom.
 (c) Recommended CR_u for design is based on a statistical best fit analysis of T_{ultconn} / T_{lot} values across all geogrid types tested.
 (d) Recommended value for 5 < pH < 8. RF_D value of 1.3 recommended for 4.5 ≤ pH ≤ 5 and 8 ≤ pH ≤ 9.

The information contained in this report has been carefully compiled by Redi-Rock International, LLC as a recommendation of peak connection capacity. It is accurate to the best of our knowledge as of the date of its issue. However, final determination of the suitability of any design information and the appropriateness of this data for a given design purpose is the sole responsibility of the user. No warranty of performance is expressed or implied by the publishing of the foregoing laboratory test results. Issue date: May 12, 2014.

REPORT
RESULTS OF
REDI-ROCK POSITIVE CONNECTION (PC) BLOCK
AND MIRAGRID 8XT
GEOGRID
CONNECTION CAPACITY TESTING

submitted to

REDI-ROCK INTERNATIONAL

CONFIDENTIAL

Distribution:

2 copies REDI-ROCK International LLC.
05481 US 31 South
Charlevoix, Michigan 49720
USA

2 copies Bathurst, Clarabut Geotechnical Testing, Inc.
1167 Clyde Court, Kingston, Ontario
K7P 2E4 CANADA

This report shall not be reproduced except in full, without written approval of Bathurst, Clarabut Geotechnical Testing, Inc.

Introduction

This report gives the results of a connection testing program carried out to evaluate the mechanical/frictional performance of the connection between Redi-Rock Positive Connection (PC)TM Block modular concrete units manufactured by Redi-Rock International, LLC and Miragrid 8XT[®] geogrid.

The test program was initiated in response to a verbal authorization to proceed from Mr. Jamie Johnson of Redi-Rock International, LLC received 29 November 2011.

The tests were carried out at the laboratories of Bathurst, Clarabut Geotechnical Testing, Inc. in Kingston, Ontario, under the supervision of Mr. Peter Clarabut.

Objectives of test program

The facing-geogrid connection between Redi-Rock concrete block units and Miragrid 8XT geogrid was investigated using a large-scale connection test apparatus.

The principal objective of the testing was to evaluate the frictional/mechanical performance of these connections. A second objective was to make preliminary recommendations for the selection of long-term tensile connection capacities to be used in the design and analysis of geogrid-reinforced soil wall systems that employ Redi-Rock blocks in combination with Miragrid 8XT geogrid.

Materials

The Redi-Rock Positive Connection (PC) Block units used in this investigation are solid concrete blocks. The nominal dimensions of the blocks are 28 inches (toe to heel) by 18 inches high by 46 inches long and weigh approximately 1625 lb per unit. Construction alignment and wall batter is achieved by means of two dome-shaped concrete shear keys cast into the top surface of the units. The Redi-Rock block system employs a rectangular hole in the block to mechanically attach the geogrid reinforcement. The rectangular hole is centrally located across the block length and located 10 inches from the back of the block. The blocks used in this series of tests were supplied by Redi-Rock International and were received at our laboratory on 9 August 2011 and designated as BIC-11-025.

Miragrid 8XT is a coated bi-directional grid composed of 100% polyester multifilament yarn with a tensile strength of 7400 lb/ft in the machine direction (based on ASTM D 6637 method of test and reported on the manufacturers' website - www.tencate.com on 28 November 2011). The geogrid used in this series of testing was delivered as 12 inch wide (11 strands), specimens from roll/lot # 031140138 received at our laboratory on 17 November 2011. The index strength of roll/lot # 031140138 was 8,055 lb/ft (test data supplied by TC Mirafi).

Apparatus and general test procedure

The method of test used in this investigation follows that reported by Bathurst and Simac (1993) and recommended by the NCMA (Simac et al. 1993) and ASTM D 6638. A brief de-

scription of the apparatus and test methodology is presented here. The test apparatus used to perform the tests is illustrated in **Figure 1**. The test apparatus allows tensile loads of up to 35,000 pounds to be applied to the geogrid while it is confined between two block layers. The facing block was laterally restrained and surcharged vertically. A strip of geogrid reinforcement 12 inches wide (11 longitudinal strands) was passed through the block and both ends were attached to roller clamps. The connection detail and roller clamp arrangement is illustrated in **Figure 2**. A photograph of the Redi-Rock Positive Connection (PC) Block system and the recommended geogrid connection configuration is shown in **Figure 3**. The hollow slot portion of the block was infilled with a 3/4 inch, 100% crushed limestone aggregate and lightly compacted. **Figure 4** illustrates the particle size distribution of the infill used in this test series. Two wire-line LVDT(s) were connected to the lower grid to measure grid displacement at the back of the block. Wall heights were simulated by placing one block over the interface and applying an additional surcharge load using the vertically-oriented hydraulic jack shown in **Figure 1**. Gum rubber mats were placed over the top block to ensure a uniform distribution of vertical surcharge pressure. The connection force was applied at a constant rate of displacement (i.e. 0.75 inch/minute) using a computer-controlled hydraulic actuator. The load and displacements measured by the actuator and the LVDT(s) were recorded continuously during the test by a microcomputer/data acquisition system. All blocks used in the tests were visually inspected to confirm that they were free of defects. Each test was continued until there was a sustained loss in connection load due to grid rupture. Following each test, the block was removed and the grid examined to confirm failure modes. A virgin specimen of grid was used for each test.

The only variable in this series of connection tests was the magnitude of surcharge load.

Test program

The surcharge loads used in the test program are given in **Table 1**. Also tabulated are the failure loads observed for each test.

Test results

A summary of tensile loads at peak capacity is given in **Figure 5**.

The peak connection capacity between Redi-Rock Positive Connection (PC) Block units and Miragrid 8XT for walls between 241 and 4551 lb/ft normal load, ranged between 100 and 109% of the index tensile strength of the specimen of Miragrid 8XT used in this investigation (8,055 lb/ft - value reported by manufacturer for material used in this investigation).

Two repeat tests were performed and results in **Figure 5** illustrate that there is some variability in connection capacity between nominal identical tests. The variability is 3.9% and hence within the $\pm 10\%$ of the mean peak load criterion required by the NCMA. This variability is likely the result of small differences in the setting up of the blocks and laying out of the geogrid reinforcement. The trend in data for peak connection loads has been plotted using a linear curve.

All tests ended in rupture of one or more longitudinal geogrid members. There was evidence of slippage of the grid within the concrete block-grid interface in all tests. Grid straining and slippage caused abrasion of longitudinal members as the geogrid was pulled across the concrete surfaces.

Implications to Redi-Rock Positive Connection (PC) Block design and construction with Miragrid 8XT geogrid

The long-term design connection capacity in the field must be less than the peak capacity envelope determined in this test series for the same method and quality of construction. The NCMA Segmental Retaining Wall Design Manual (First Edition, 1993) recommends that the design connection capacity at a given surcharge load for a critical wall structure be the lesser of the peak capacity divided by a minimum factor of safety (not less than 1.5) or the capacity based on a 3/4 inch displacement criterion. The *design* curve in **Figure 6** has been selected based on peak capacity load data only.

The design capacity envelope illustrated in **Figure 6** should be used with caution. The actual design capacity envelope should be lower if the quality of construction in the field is less than that adopted in this controlled laboratory investigation and/or lower quality concrete is used in the manufacture of the blocks. For example, the interface concrete surfaces should be free of debris before placement of grid and blocks in order to minimize abrasion to the grid and to maximize the frictional resistance that is developed at the concrete block-grid interface.

It is very important that production blocks have uniform dimensions so that there is no stepping at the block joints that can lead to non-uniform frictional resistance at the block-grid interface, pinching of the grid at the block edges and possibly fracture of the concrete units.

Summary of conclusions

A laboratory testing program was carried out to evaluate the mechanical/frictional connection performance of Redi-Rock modular block facing units in combination with Miragrid 8XT. The following conclusions can be drawn:

1. The peak connection capacity between Redi-Rock Positive Connection (PC) Block units and Miragrid 8XT geogrid for walls between 241 and 4551 lb/ft normal load, ranged between 100 and 109% of the index tensile strength of the specimen of Miragrid 8XT used in this investigation (8,055 lb/ft - value reported by manufacturer for material used in this investigation).
2. The trend in data for peak connection loads has been plotted using a linear curve. In addition, some variability in strength values was observed between nominal identical tests due to small differences in setting up of the blocks and laying out of the geogrid reinforcement.
3. Care must be taken during the installation of Redi-Rock Positive Connection (PC) Block units in order to prevent accumulation of soil and rock debris at the concrete block-grid

interface surfaces. This debris may significantly reduce the capacity of the Redi-Rock facing unit-grid system.

4. The design envelope in **Figure 6** is based on an interpretation of test data as recommended in the NCMA Segmental Retaining Wall Design Manual (First Edition, 1993). The choice of design connection strengths may vary from site to site and quality of construction in the field may require lower design values than those taken from **Figure 6**.



P. Clarabut

REFERENCES

ASTM D 6638-01. Standard Test Method for Determining Connection Strength between Geosynthetic Reinforcement and Segmental Concrete Units (Modular Concrete Blocks), American Society for Testing and Materials, West Conshohocken, PA 19428-2958 USA.

Bathurst, R.J. and Simac, M.R., 1993. Laboratory Testing of Modular Unit/Geogrid Facing Connections, *ASTM Symposium on Geosynthetic Soil Reinforcement Testing Procedures*, San Antonio, 19 January 1993.

Simac, M.R., Bathurst, R.J., Berg, R.R. and Lothspeich, S.E., 1993. *NCMA Segmental Retaining Wall Design Manual (First Edition)*, National Concrete Masonry Association, 2302 Horse Pen Road, Herndon, VA 22071-3406.

Table 1:

Test Program:

Redi-Rock Positive Connection (PC) Block unit - Miragrid 8XT polyester geogrid connection

Test number	normal load (lb/ft)	peak horz. load (lb/block)	peak tensile capacity per single strip (lb/ft) (note 1)	observed failure mode
1	1960	15990	7995	Rupture
2	241	15898	7949	Rupture
3	1125	15807	7904	Rupture
4	2036	15898	7949	Rupture
5	2914	16538	8269	Rupture
6	3715	15990	7995	Rupture
7	1900	16903	8452	Rupture
8	4551	16538	8269	Rupture

Note: 1) The load recorded at the actuator is twice the value shown here.

LEGEND

- | | | | | | |
|---|----------------------------|----|--------------------|----|--|
| 1 | Redi-Rock block | 6 | guide rail | 11 | platform |
| 2 | geogrid | 7 | LVDT clamp | 12 | wire-line LVDT |
| 3 | loading platen | 8 | surcharge actuator | 13 | computer controlled hydraulic actuator |
| 4 | roller clamps | 9 | loading frame | 14 | stiff gum rubber mat |
| 5 | lateral restraining system | 10 | spacers | | |

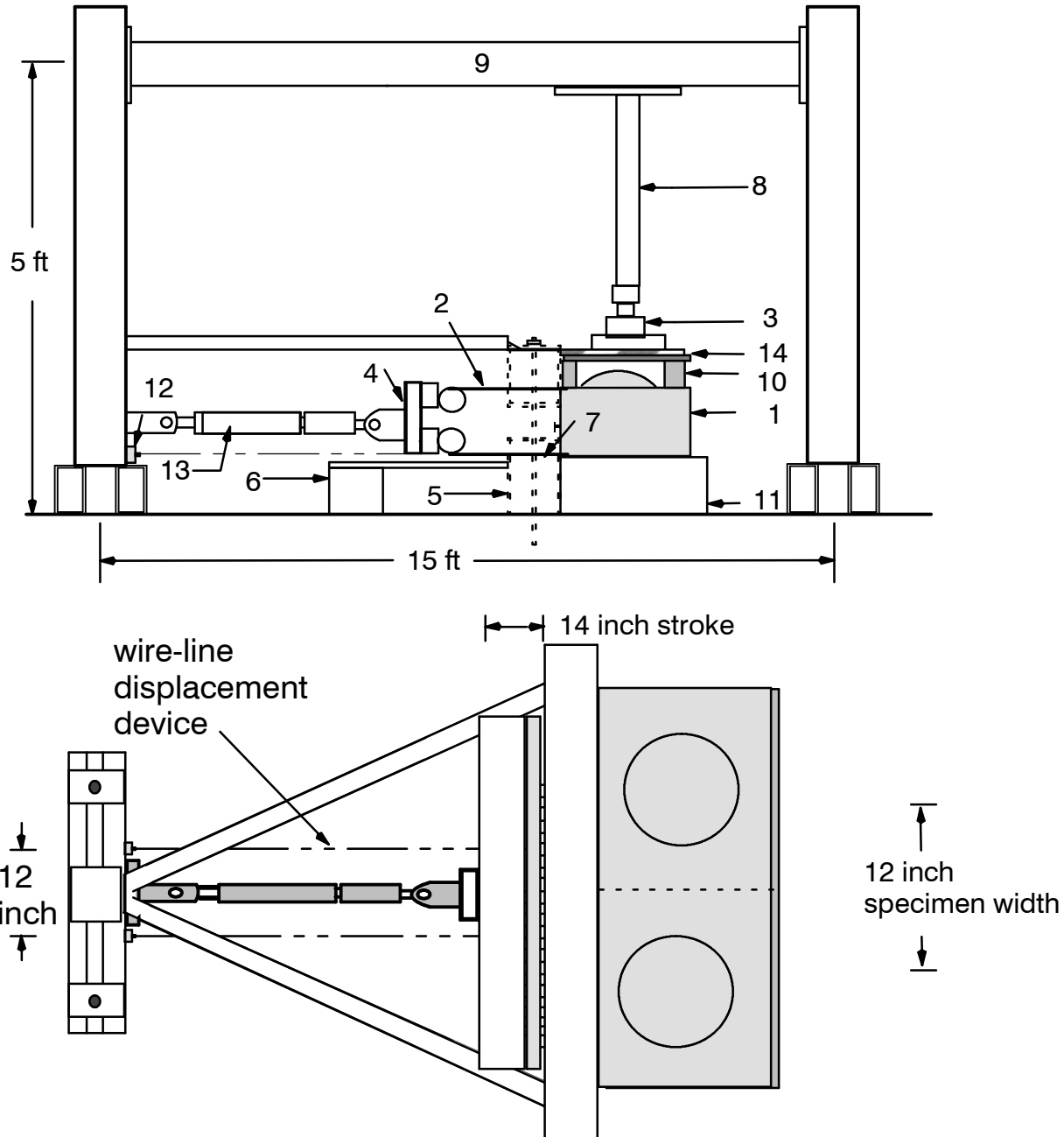

Figure 1: Schematic of connection test apparatus showing Redi-Rock Positive Connection (PC) Block units and Mirafi geogrid

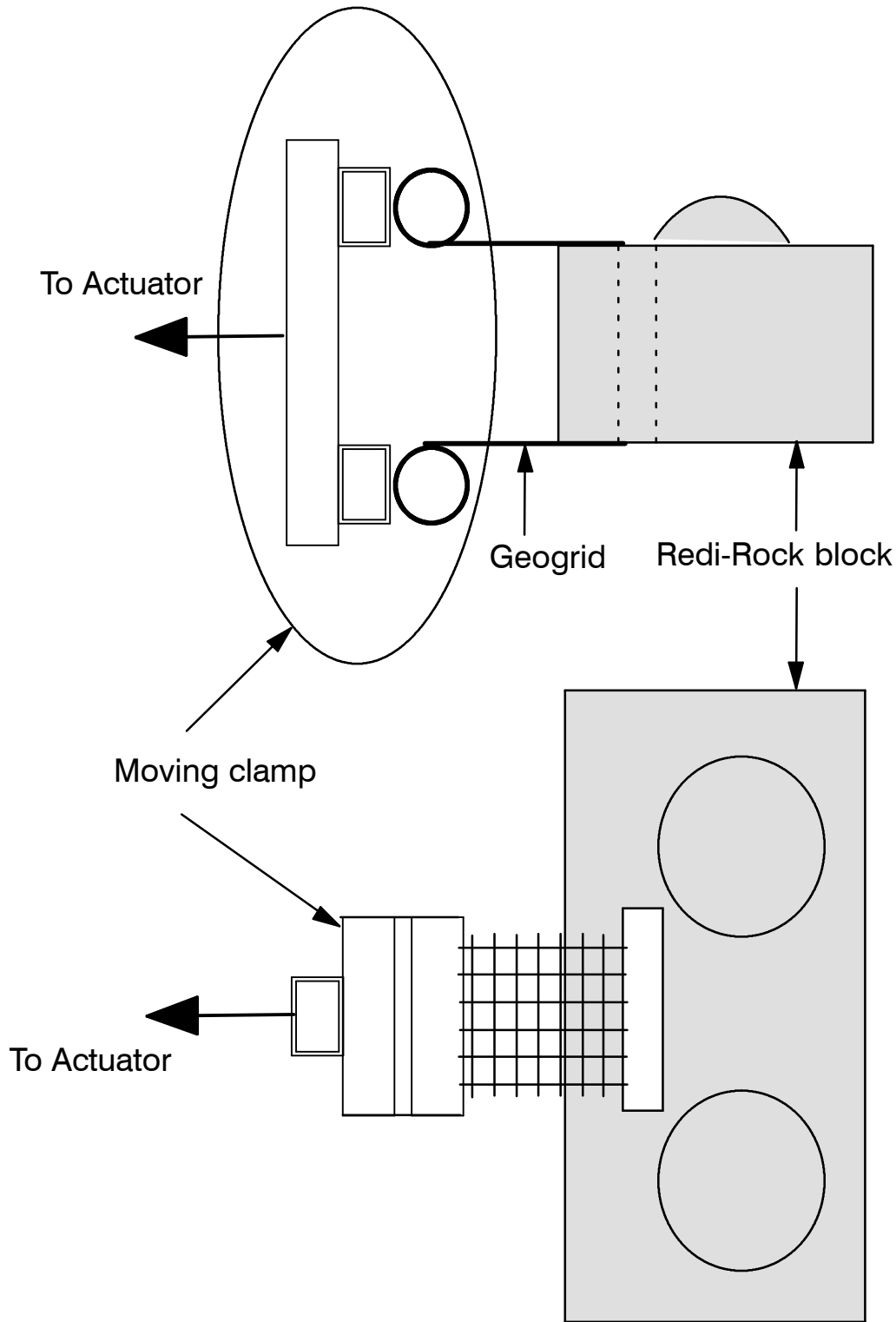

Figure 2: Schematic of connection detail and clamp arrangement

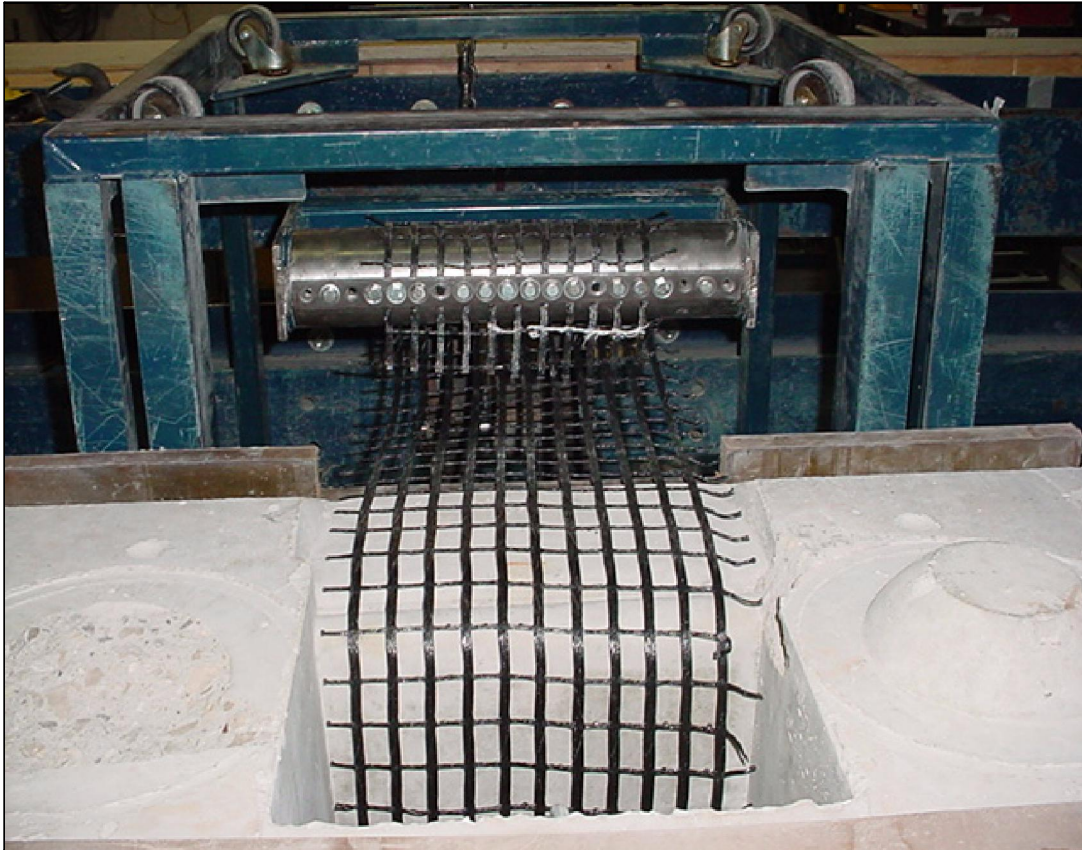

Figure 3: Photograph of the Redi-Rock Positive Connection (PC) Block system and Miragrid 8XT geogrid

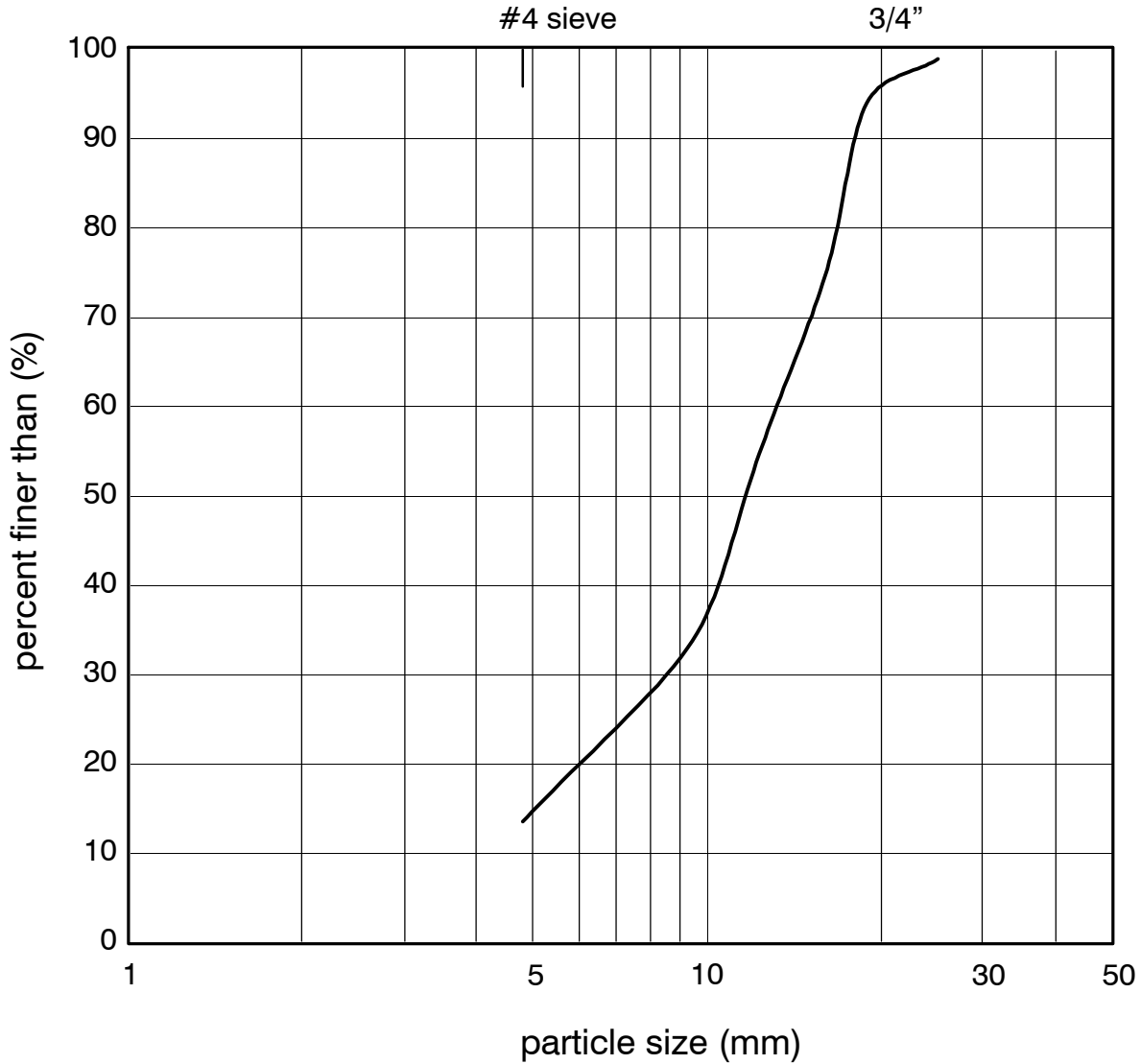

Figure 4: Particle size distribution for 100% crushed granular stone used in Redi-Rock Positive Connection (PC) Block tests

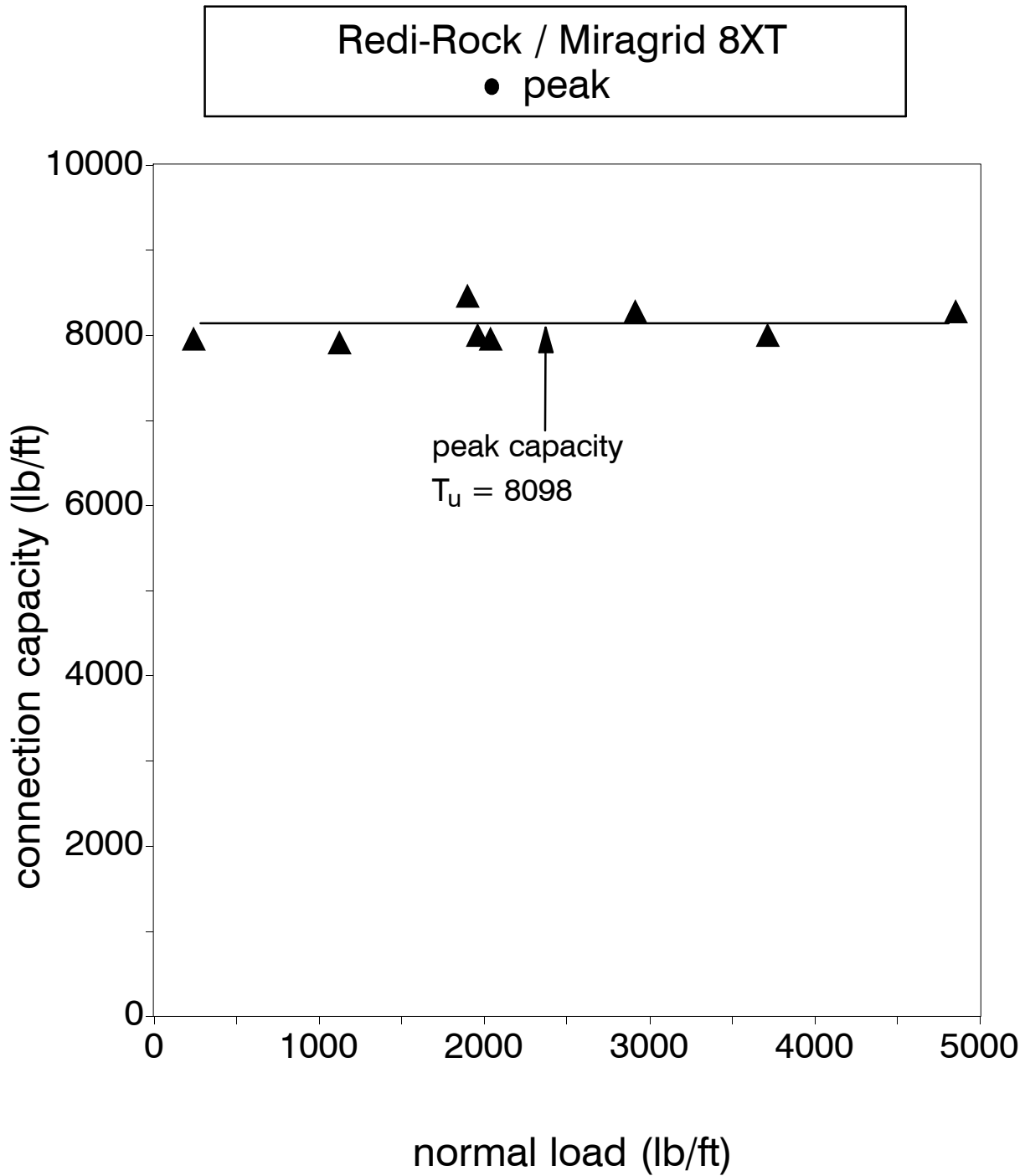

Figure 5: Connection capacity versus normal load for Redi-Rock Positive Connection (PC) Block with Miragrid 8XT based on a 12 inch wide strip of geogrid

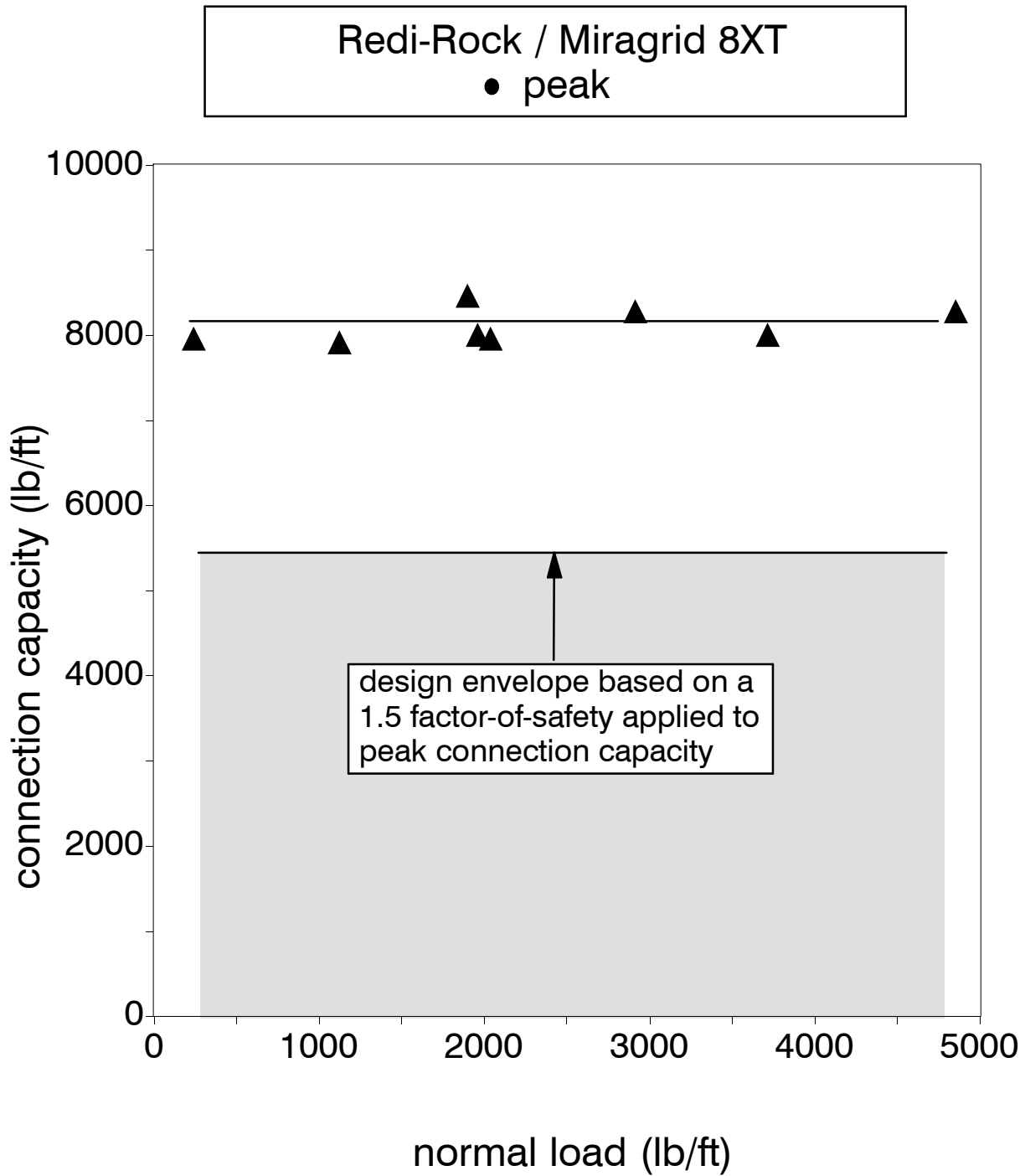

Figure 6: Preliminary design capacity envelope for Redi-Rock Positive Connection (PC) Block units with Miragrid 8XT geogrid based on a 12 wide inch strip of geogrid